

Skráningartafla: Skólabraut 31, Akranesi					Skrásetjari: Guðlaugur I. Mariasson												
Landnúmer: 132075					Kennitala: 160970-4729												
Matshlutanúmer: 02					Útgáfa: 4.01b Dags: 22.2.2017												
Uppskipting og lýsing					Stærðir												
D0	D1	D2	D3	D4	D5	D5M	D6	D7	D8	D9	D10a	D10b	D11	D12	D16	Reiknitala	D17
Lokun	Rými hæð-röð	Notkun texti	Höfuð-flokkun	Eignar-hald	Botnflötur m²	Milflötur m²	Stigar m²	Op m²	Brúttóflötur m²	Brúttóflötur sh < 1,8	Salarhæð mín	Salarhæð max	Brúttó rúmmál m³	Nettóflötur m²	Birt flatarmál m²	Reiknitala skiptarúmmáls	Skiptarúmmál m³
		Matshluti			40,9	0,0	0,0	0,0	40,9	0,0			121,4	35,0	40,9		96,950
		Botn											8,2				
A	01 0101	1. hæð Garðhús	N	0101	40,9	0,0	0,0	0,0	40,9	0,0	2,55	2,97	113,2	35,0	40,9	2,77	96,950
		Athugasemdir															
		Sameignir sumra															
Eignarhald																	
Eignar-hald	Notkun texti	Birt flatarmál m²	Skiptarúmmál Séreign m³	Séreign og sameign m³													
0101	Garðhús	40,9	96,950	96,950													
	Alls	40,9	96,950	96,950													

Skólabraut 31, Akranesi - Landnr.: 132075
Garðhús úr timbri - Mhl 02 - Reyndarteikning
Afstöðumynd og skráningartafla

Teikningarnúmer		Reyndarteikning			
Staðgreinir	Aðaluppdráttur	Land.nr.	Mhl.	Verk.nr.	ÍB-17-13
Staðgreinir	3000-1-00086708	132075	02	150550-4759	
Flannað	Teiknað	GIMMHÓI	Breyting	1.01	Útgáfa A
Kvarði	Dags.	22. febrúar 2017	Undirtektun		
1.500					
MarkSTOFA ehf.		Magnús H. Ólafsson arkitekt FAÍ			
Markkerfið 18, 300 Akranesi - s: 4314210 8932002		150550-4759			
		mark@isholf.is			

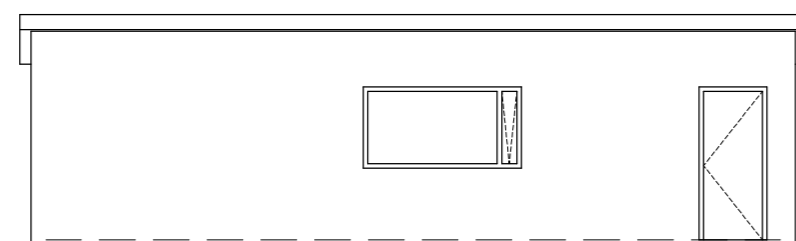

Suðurhlíð

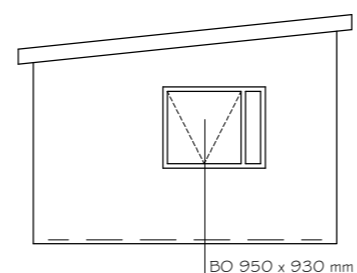

Vesturgafi

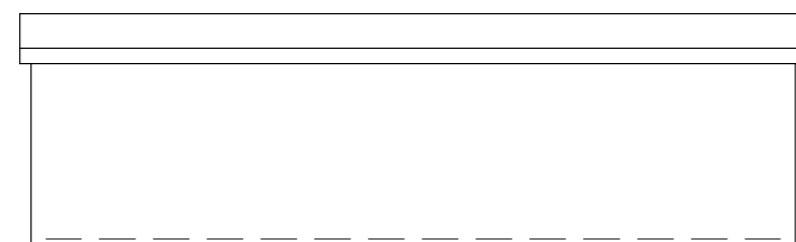

Norðurhlíð

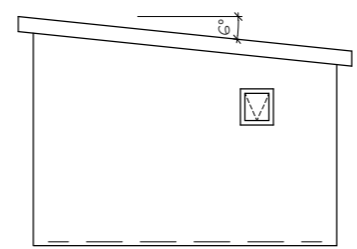

Austurgafi

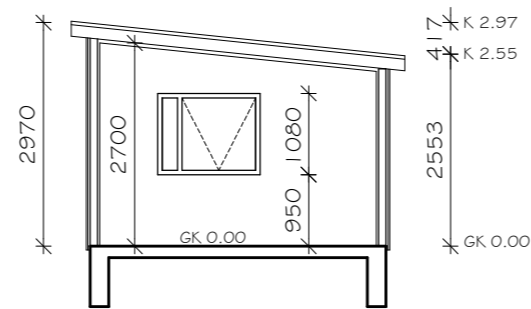
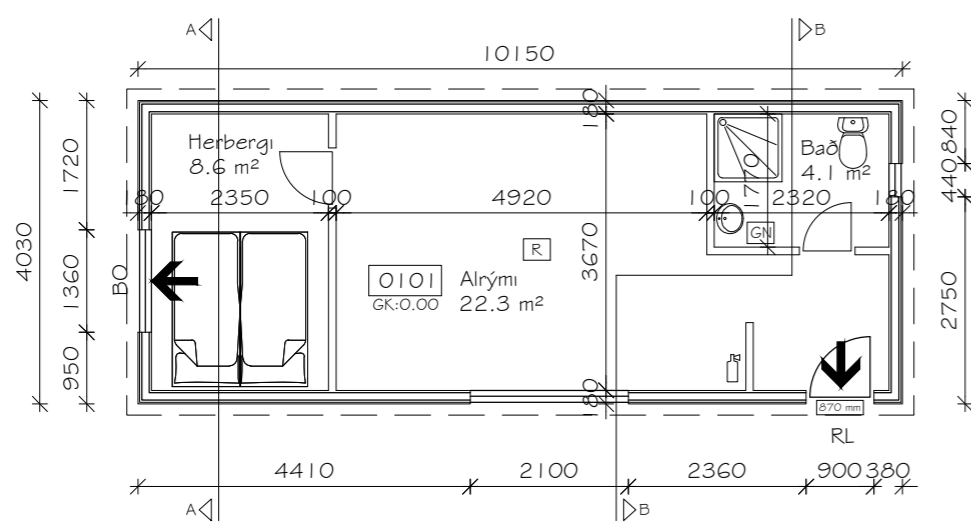

Snið A-A

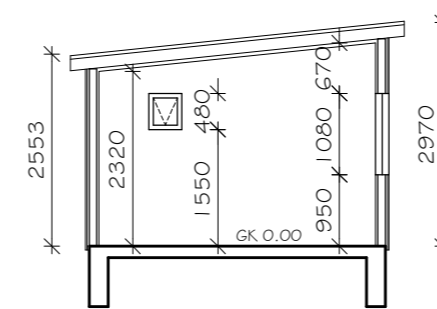

Snið B-B

Skýringar

- ← Flóttastefna í rýmingarleiðum
- RL Rýmingarleið
- BO Björgunarop
- R Reykskinjari
- GN Gólfniðurfall
- Slökkvitæki

Skólabraut 31, Akranesi - Landnr.: 132075
 Garðhús úr timbri - Mhl 02 - Reyndarteikning
 Grunnmynd, snið og útlit

Teiknategund	Aðaluppdráttur	Reyndarteikning					
Staðgreinir	3000-1-00086708	Land.nr.	132075	Mhl.	02	Verk.nr.	ÍB-17-13
Plánað		Teiknað	GIMMHÓI	Teikn.nr.	1.02	Útgáfa	A
Kvarði	1.100	Dags.	22. febrúar 2017	Breyting		Undirritun	
MarkSTOFA ehf.		Magnús H. Ólafsson arkitekt FAÍ 150550-4759 mark@sholf.is					
<small>Markgerðir 18, 300 Akranes - s: 4314210 8932002</small>							